

alien *x*

# 3D *READY*



eurocolumbus  
C-ARM EVOLUTION

# Alien X 3D Ready: the most complete C-arm on the market

**Alien X 3D Ready** is equipped with the most advanced software to offer unrivalled performance:

- **Three-dimensional capture:** for detailed and accurate images in real time thanks to **reco<sup>3</sup>tom<sup>®</sup>** by MedCom libraries. *(optional)*
- **Fusion:** integrates three-dimensional images with two-dimensional images for a more precise diagnosis. *(optional)*
- **Synchro:** monitors the position of our CT70 T Evolution imaging bed in space, ensuring perfect synchronisation. *(optional)*

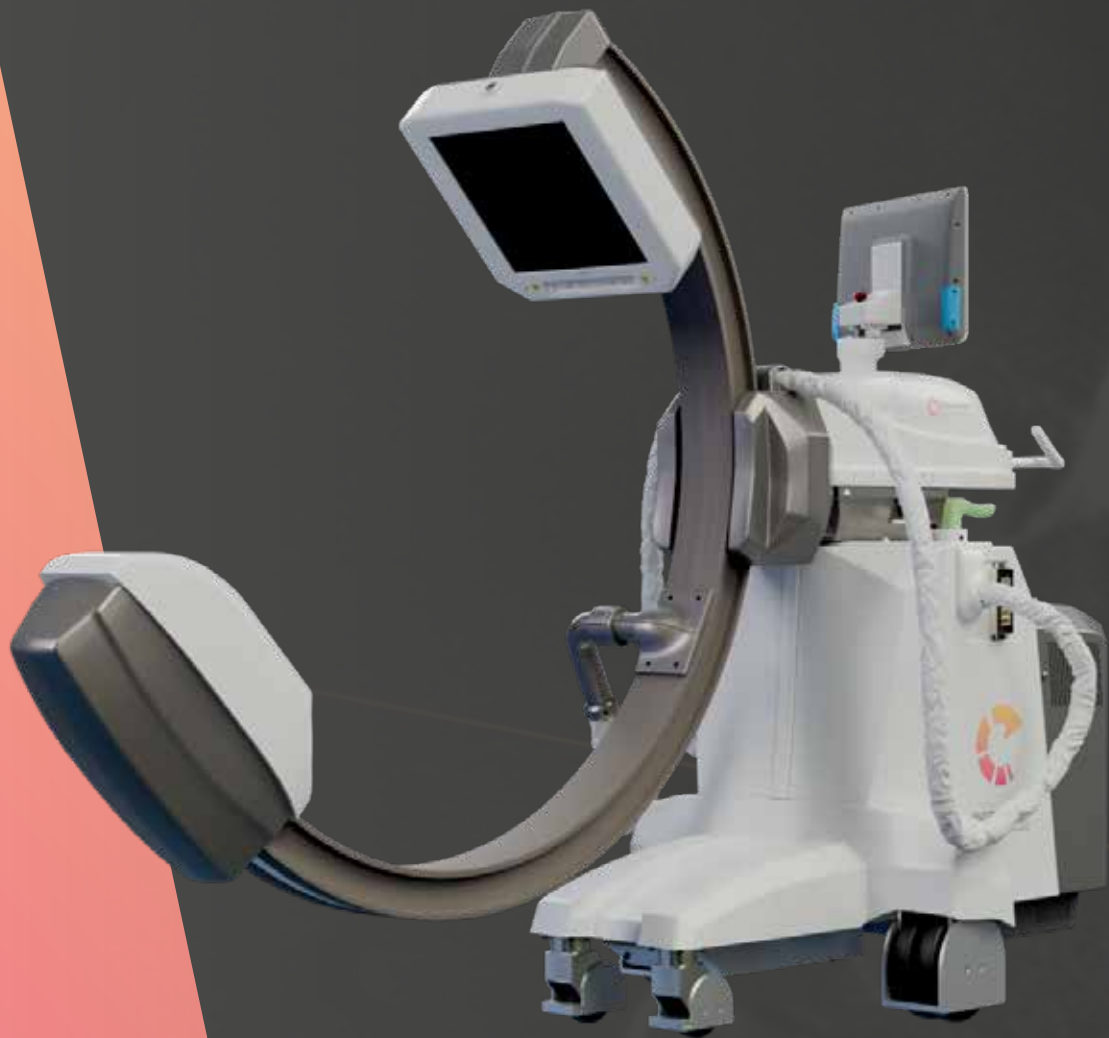

**NO  
MONO  
BLOCK**

**YES**  
**GENERATOR**  
**SEPARATED FROM THE TUBE**

# High frequency generators

EuroColumbus developed the EPB and EPA systems specifically for clinical applications that require high instantaneous power peaks, allowing energy to be drawn from existing electrical systems equipped with 13 - 16 A electrical sockets.

## Why don't we use the monoblock system?

Because only in this way is it possible to use tubes that have higher anode capacities and are smaller than those of monoblock technology. In a monoblock system, the heat produced by the X-ray tube is added to that produced by the generator.

Obviously, if the housing has the same declared dissipation as a system with a generator separated from the X-ray tube, the monoblock system is less efficient because the total dissipation does not cool the tube alone, but also cools the monoblock system that includes the generator.

The system with a separate generator therefore guarantees better cooling of the X-ray tube with the same dissipation of the housing.



**EPB** (*Eurocolumbus Power Boost*) is an energy reserve that stabilises the voltage and increases the performance of the inverter to avoid fluctuation during long and demanding radiological emissions.



**EPA** (*Eurocolumbus Pulse Advanced*) is a function that creates 0.5 to 30 pulses or images per second, a wide range of possibilities to guarantee images without a slow motion effect with the option of automatic variation.

A blue frame grabber device with a black screen and a black cable. The device is shown from a slightly angled perspective, highlighting its front panel and the screen area. The cable is thick and black, extending from the top left towards the device.

**Frame  
grabber**

**10**  
**GigaBites**

# 3131

*pixel size*

**100 microns**

**IGZO**

It is the top of the range on the market, operating in **3Kx3K** full resolution scopy to provide extremely well defined and contrasting images, thanks to the new scintillators.

**The proprietary 10 GB frame grabber guarantees exceptional capture speed.**



**Also available:**

# 3030

*pixel size*

**151,8 microns**

**CMOS**

# 3030

*pixel size*

**145 microns**

# Tubi RX

**alien X 3D** uses the latest generation X-ray tubes with Titanium, Zirconium and Molybdenum (TZM) plate. The advantages compared to the use of plates made of pure Molybdenum are better creep resistance, higher recrystallisation temperature and high heat resistance.

# New Cooling System

**WAD** (*Water Aided Dissipation*) is an X-ray tube cooling system. Thanks to the combination of the management of the dielectric oil inside the X-ray tube, the refrigerant liquid and the advanced heat exchanger, the system does not use fans.

**EHC** (Eurocolumbus Heat Control) allows one to quickly edit the frame/sec, pulse rate and radiological and imaging parameters in real time in order to keep the heat produced under control in order to ensure optimal operation of the system and avoid overheating.

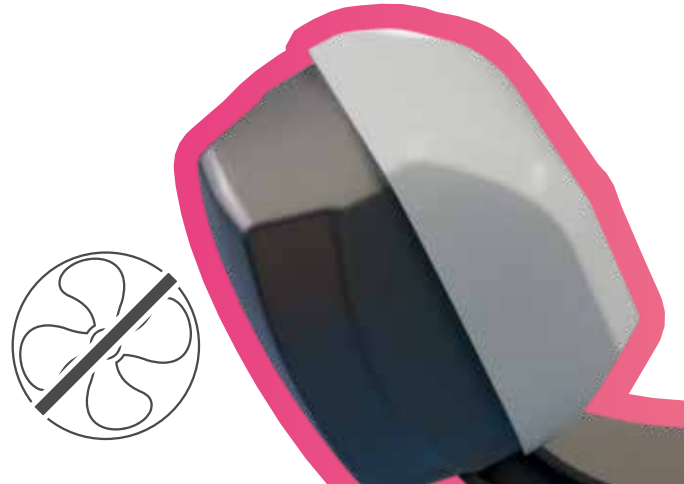





# On the Operator's side:

# ***ERGONOMICS***

The twin wheels made of antistatic material and with minimal footprint on the floor, as well as the optimal weight distribution and the ergonomic handles with perfect force distribution, make alien X easy to move and operate.

These simple measures mean that the device can be positioned without difficulty, even under the operating table

alien X is perfectly balanced in every position, with the option to store up to four positions of the arm as well as the zero positions. When the instrument is in motorised mode, the movements are synchronised with each other and, thanks to the anti-collision sensors on the sides of the FPD and X-ray tube (the operating distance of which can be set) the chosen positions can be reached quickly and in total safety.

The position can be recalled at the simple press of a button.

Finally, alien X has colour-coded positioning handles, which help the operator to easily identify the various commands and correctly move the equipment in manual mode.



# Complete control of the system using the ETS user interface

alien X is equipped with two user interfaces (of 15.6" or 18.5"). One is positioned on the C-arm and one in the rear side of the monitor trolley. This means the technician can operate away from radiation and away from the sterile field.

The ETS enables management of all the functions of the equipment: it is easy and intuitive, and designed for user recognition (in compliance with the GDPR).

It is available as a trolley option with the third ETS that allows complete control at any point in the room and, if desired, it is possible to position it at the patient's bed with a special clamp.



# EPD anti-collision systems

Safety first! The **new EPD** (EuroColumbus Proximity Detection) volumetric systems can be set up in a different and independent manner for the sides of the FPD and X-ray tube.

The system detects the proximity of anatomical or metal parts and stops the arm immediately to avoid collision.

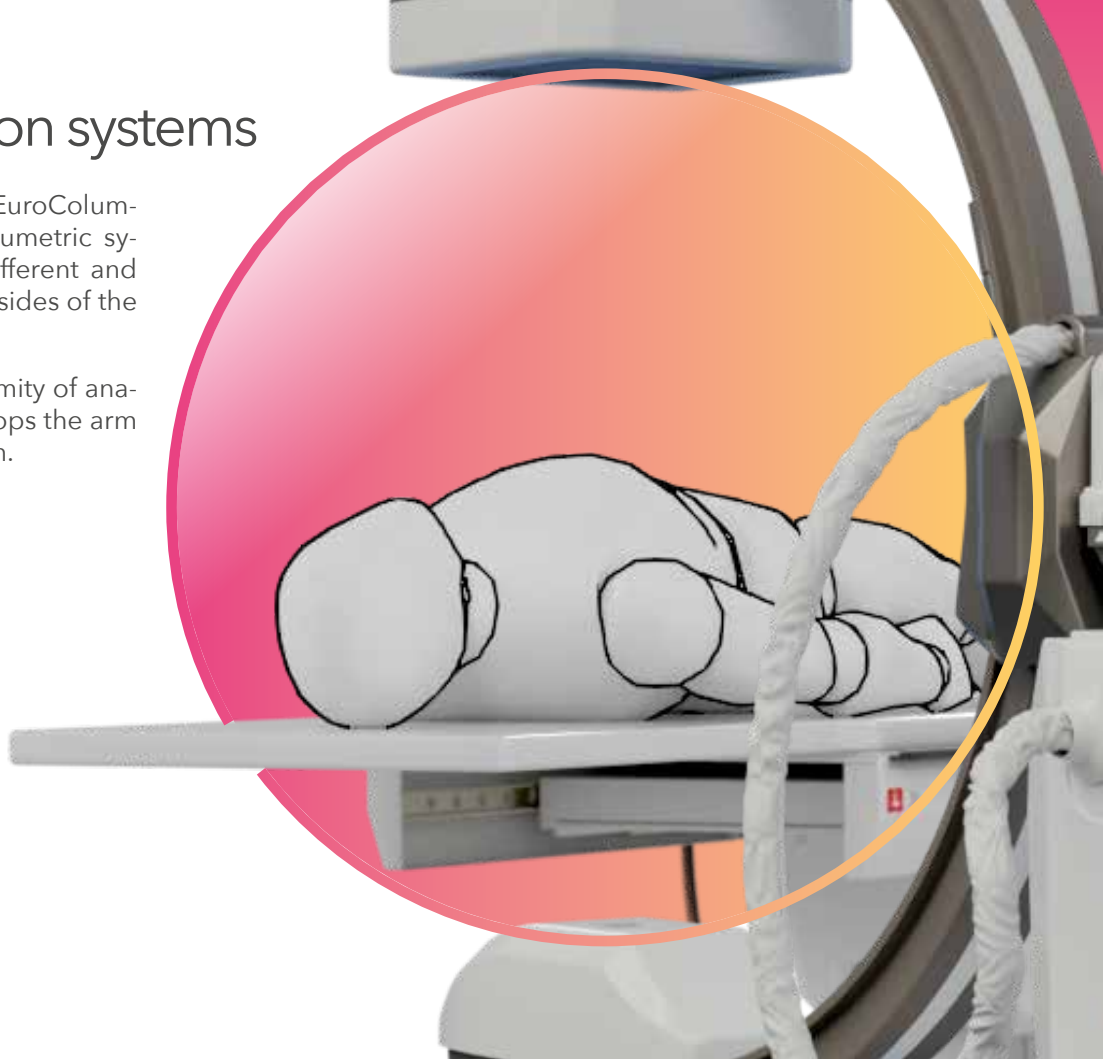

# Three-step security



alien X 3D Ready is equipped with a smart anti-collision safety system that follows a three-step procedure:



**First step:** The anti-collision system is activated and stops all movements of the arm, preventing a collision.

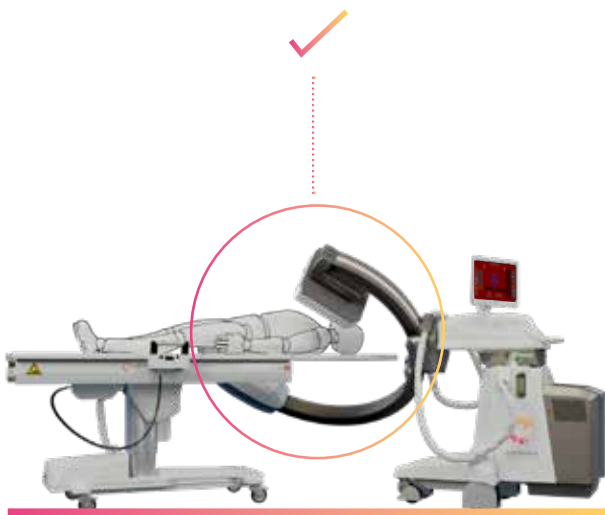

**Second step:** If the active anti-collision system intervenes during the emission of X-rays, all movements of the arm are stopped without interfering with the emission.

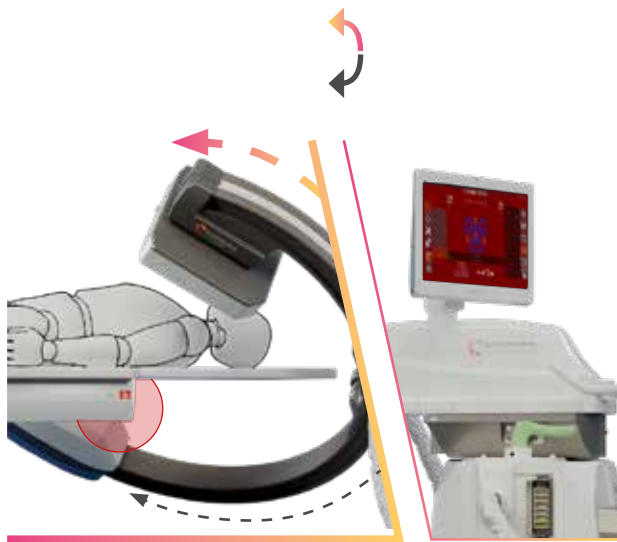

**Third step:** The system recognises the point of the avoided collision and activates only the buttons required to return to a safe position.

# Natural isocentrism or computerised EIC: You decide

EuroColumbus is the only system capable of having a “natural” isocentric geometry, as on fixed angiographic and hemodynamic systems and a computerised EIC system.

In fact, EIC ensures the combined and synchronised control of the 5 motorised movements: vertical, horizontal, RAO-LAO, CRA-CAU and SID, ensuring that the chosen projections are always in the isocentre.

The double choice allows you to solve any problem in the operating room relating to the precision of the required projections.

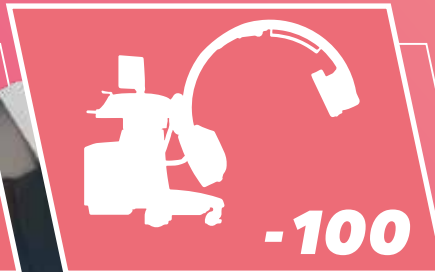
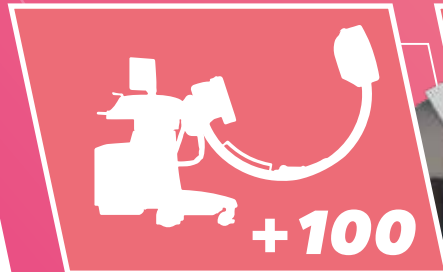



## Variable SID

The vertical and angular movements are fully motorised and the SID can also be varied during the movements: up to 4 different positions can be stored, in addition to the standard ones already saved in the software, and can be recalled at any time.

**This means that alien X 3D has the same advanced functions as an expensive fixed angiograph or a stationary hemodynamic system, but at a much lower price.**

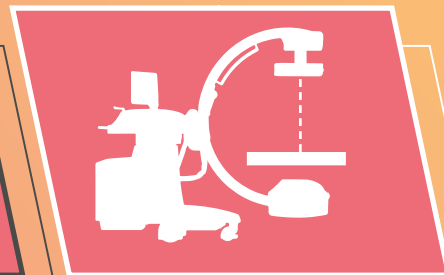
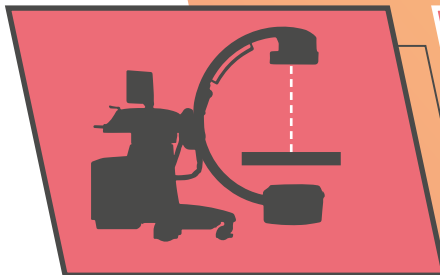



# Monitors

for the best possible experience

We are the first to use only 4K monitors.

Our monitors measure 27" or 32", are protected against accidental shocks, and can be adjusted vertically, with a motorised movement, as well as horizontally and laterally.



# Ergonomic monitor trolley

Designed to meet the operator's needs for sterility and ergonomics, EuroColumbus' new trolley measures less than 55 centimetres on each side.

The trolley has large diameter and twin wheels to ensure maximum manoeuvrability. These wheels are equipped with cable sweepers and made of antistatic material.

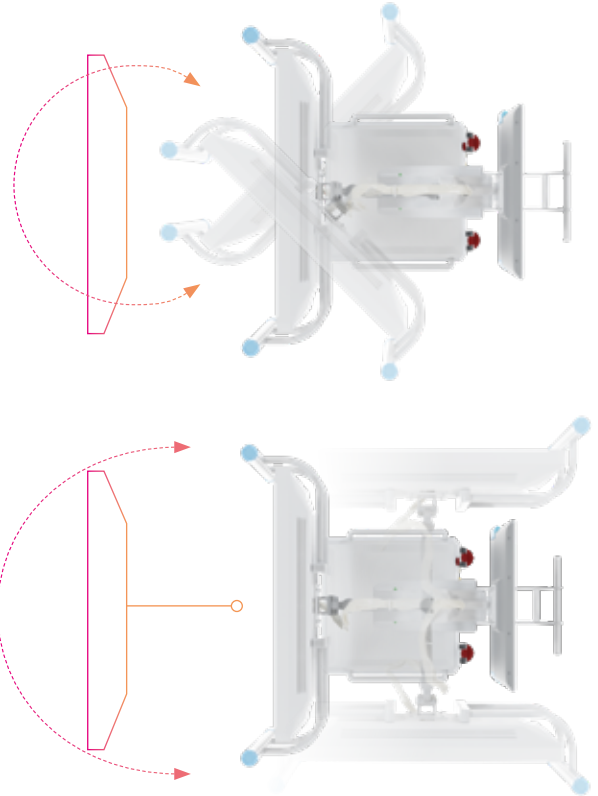





# **MULTILEVEL DOSE REDUCTION**

**Thanks to the total control at every point of the acquisition, it is now possible to obtain a perfect image and simultaneously reduce patient and operator irradiation.**



Total control at every point of the acquisition means the images are perfect even acquired at the edges and not in the centre of the detector.

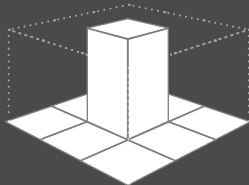

**SPOT** / *the past*

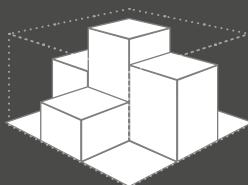

**MATRIX** / *in the 2000s*

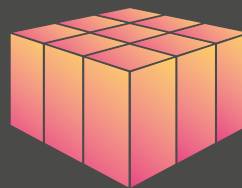

**alienX3D**  
total control at every  
point of acquisition

# Multilevel Dose Reduction

During design, we always observe the principle of **ALARA** (As Low As Reasonable Achievable) and research and adopt specific solutions to reduce the dose of X-rays as much as possible without sacrificing the diagnostic quality of the image.

To do this, we use the EuroColumbus Multilevel Dose Reduction system that includes various levels of dose reduction involving the use of tools designed in-house.

## The functions of the EuroColumbus Multilevel Dose Reduction



**EDM** (*Eurocolumbus Dose Management*) determines the correct dose with detection on every single pixel of the detector.



**EAC** (*Eurocolumbus Automatic Control*) decides the duration of the exposure even if the anatomical district is not perfectly centered.

**Both functions operate in real time, thanks to a closed-loop control of "image quality - radiological parameters".**



**ABS** (*Automatic Brightness System*) guarantees the correct brightness throughout the process.





**EDS** (*Eurocolumbus Dose Speed*) allows, once the perfect dose has been calculated, to vary the voltage in real time with a resolution of only 0.2 kV and, for the step current, of only 0.1 mA.



**ELD** (*Eurocolumbus Low Diffusion*) applies additional filters to image noise, drastically reducing the dose.



**EBF** (*Eurocolumbus Beam Filtration*) guarantees additional filtration of the X-ray beam with an additional motorised collimator. In addition to the basic filtration of 2.5 mm Al + 0.1 Cu, in fact, further filtration activity is guaranteed on the EuroColumbus C-arms with additional filters that automatically intervene for each body district and for each pre-set anatomical technique.

**There is therefore the possibility of inserting additional filters automatically or setting them very easily.**

**Additional integrated filters** greatly reduce the dose without affecting the very high quality of the images:



**01**

no additional filter



**02**

additional aluminum filter



**03**

additional fine copper filter



**04**

additional thick copper filter

# Multilevel Dose Reduction



**RDW** (*Reduction Dose Wide*), the digital rotation of the images, the storage of the position of the arm and the virtual collimator, the automatic variations of pulse/frame rate and the laser pointer on the sides of the FPD and/or X-ray tube, the extractable grid, the LED light to illuminate the sterile field to make positioning on the district to be examined easier: these are all means to guarantee a significant reduction of the dose.



Even the **variable SID** (Source to Image Distance) helps to significantly reduce the dose, allowing the flat panel to be positioned closer to the patient during irradiation without having to lower the entire C-arm). It also makes it easier and more convenient for the medical personnel to work, as they are able to quickly move the detector away from the patient. The variable SID also makes it possible to use an arm with a high depth while keeping the dimensions small, in order to facilitate access of the patient and all types of movement. This minimises the risks deriving from the vertical movement of the operating bed.

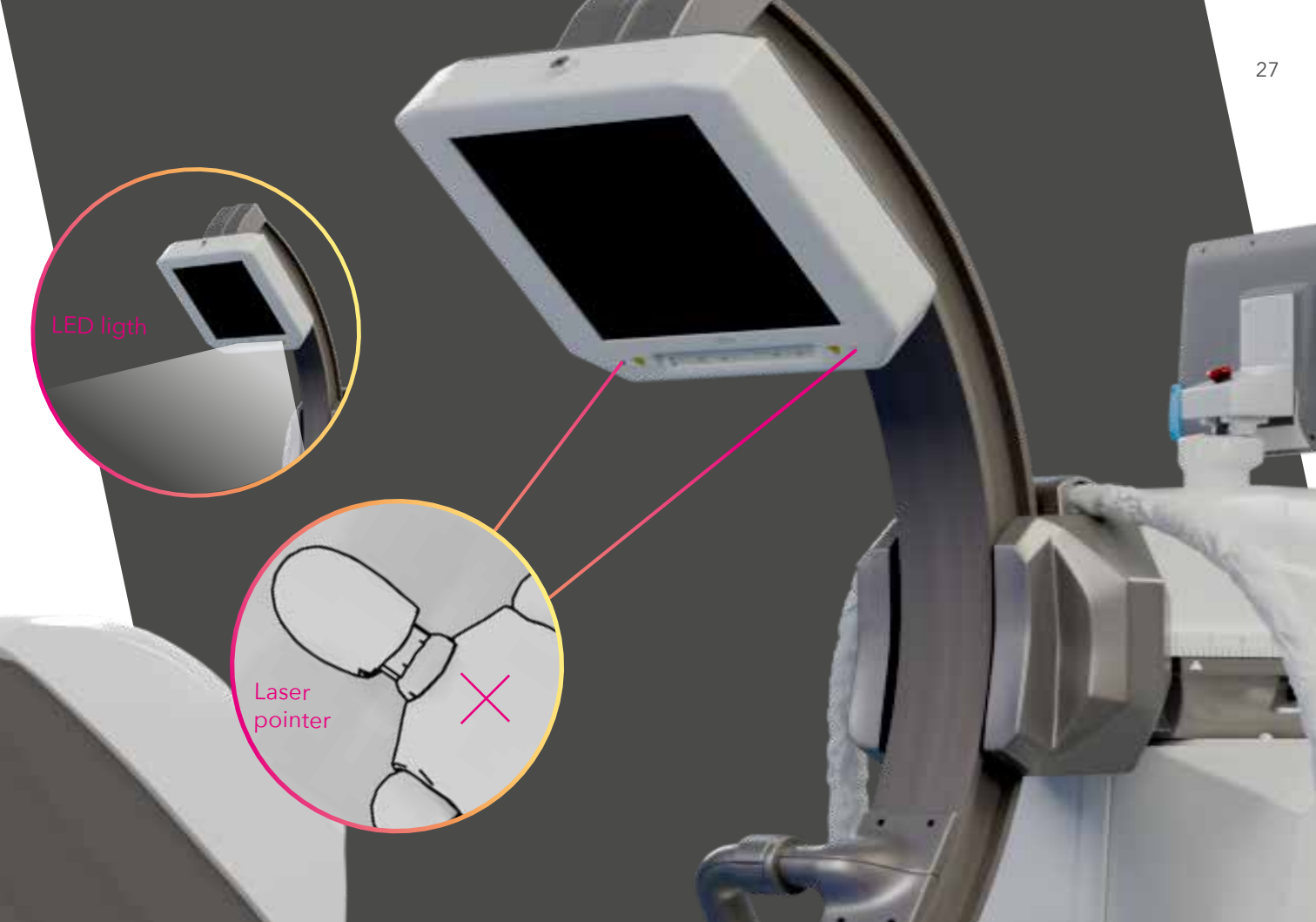
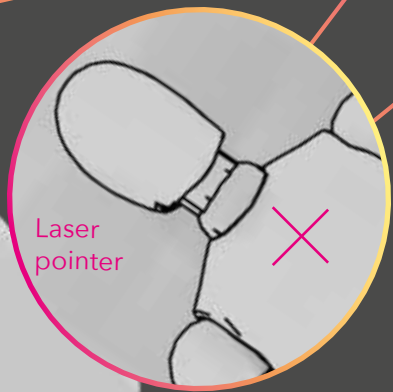

# 3D Imaging

Scan scheme .....	<b>Iso-centric</b>
Projections for 3D reconstruction .....	<b>Up to 400</b>
3D volume size.....	<b>16 cm x 16 cm x 16 cm option up to 30</b>
3D volume resolution.....	<b>512 x 512 x 512 pixels</b>
Acquisition time.....	<b>Not more of 30 seconds, reconstruction 30 sec</b>
3D viewing .....	<b>Simultaneous display of 3 projections (transversal, coronal and sagittal)</b>
3D volume rendering .....	<b>Yes</b>
Metal artefact reduction .....	<b>Yes</b>
Library.....	<b>Recotom® by MedCom</b>

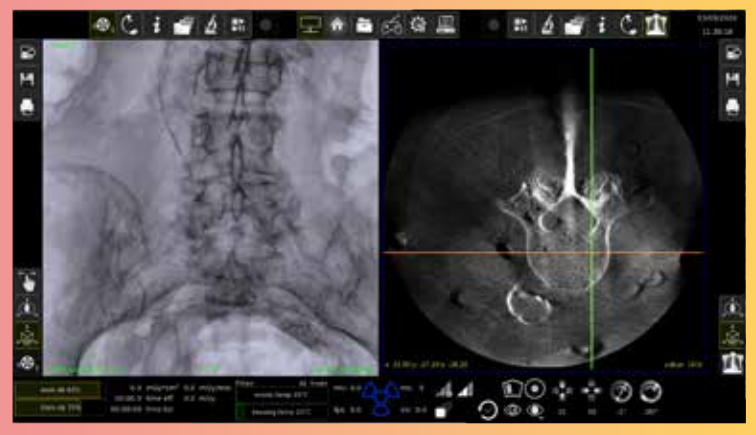
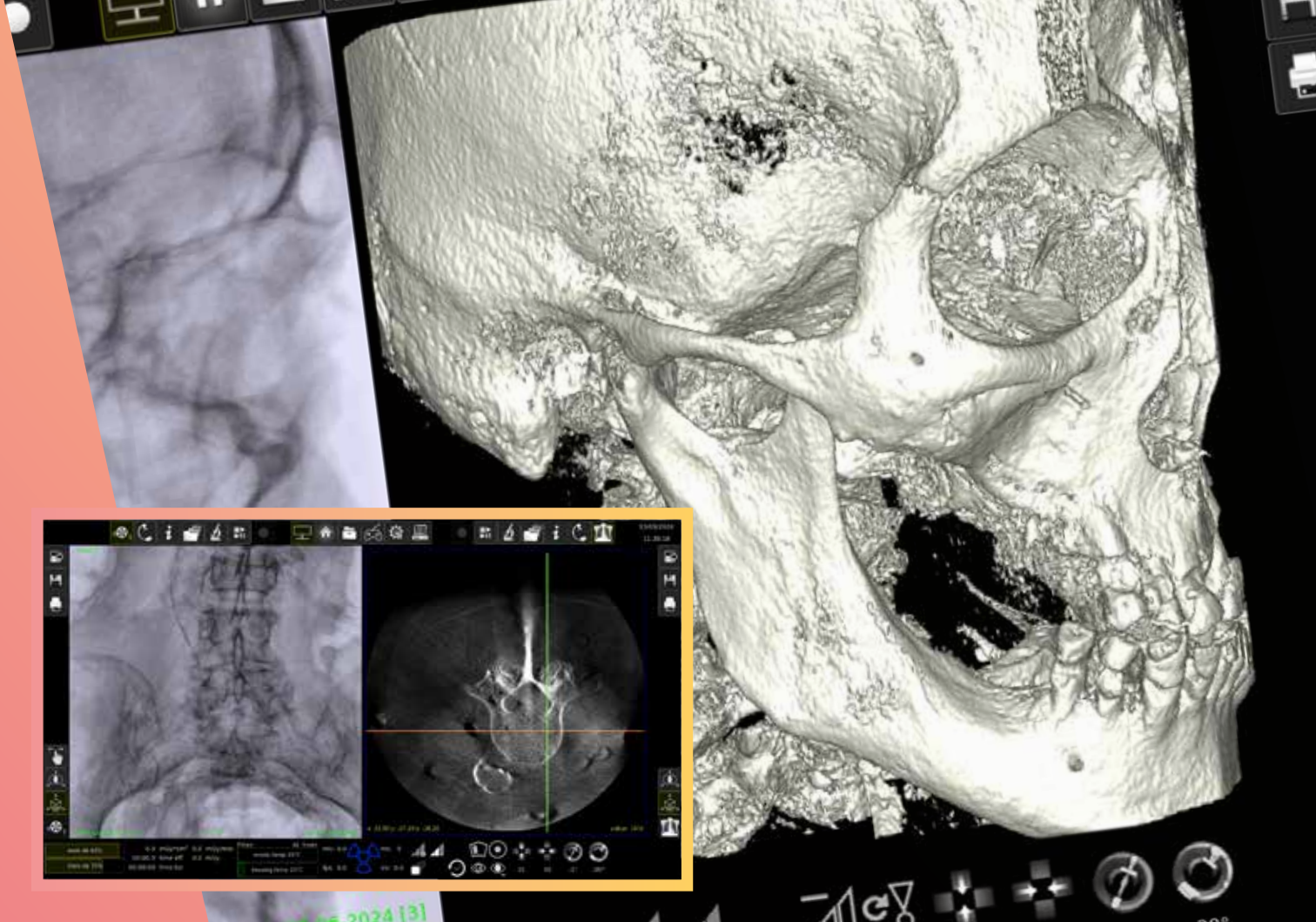



# ESG

(eurocolumbus safety guide)



Guide wires, pins and K-wires have played an important part in orthopaedic operations in recent decades. For example, the Steinmann Pin is used for fixing bone fractures and reconstructing bones or as a guide for inserting other implants.

While the Kirschner wires (K-wires) are used as anchors for skeletal traction.

The correct positioning of the guide wires and the speed of execution is therefore essential for the success of the surgery and the reduction of risks to the patient.

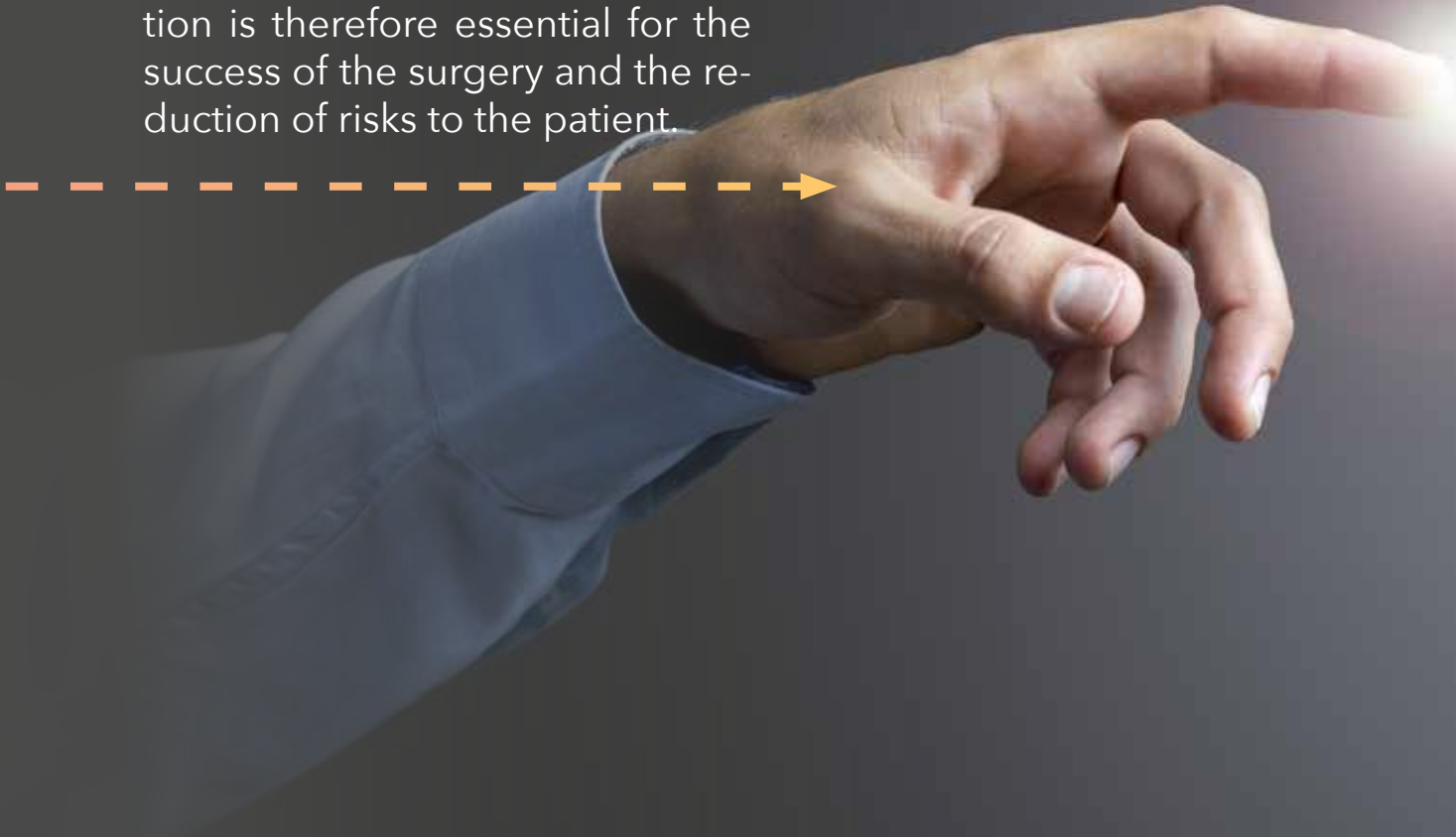



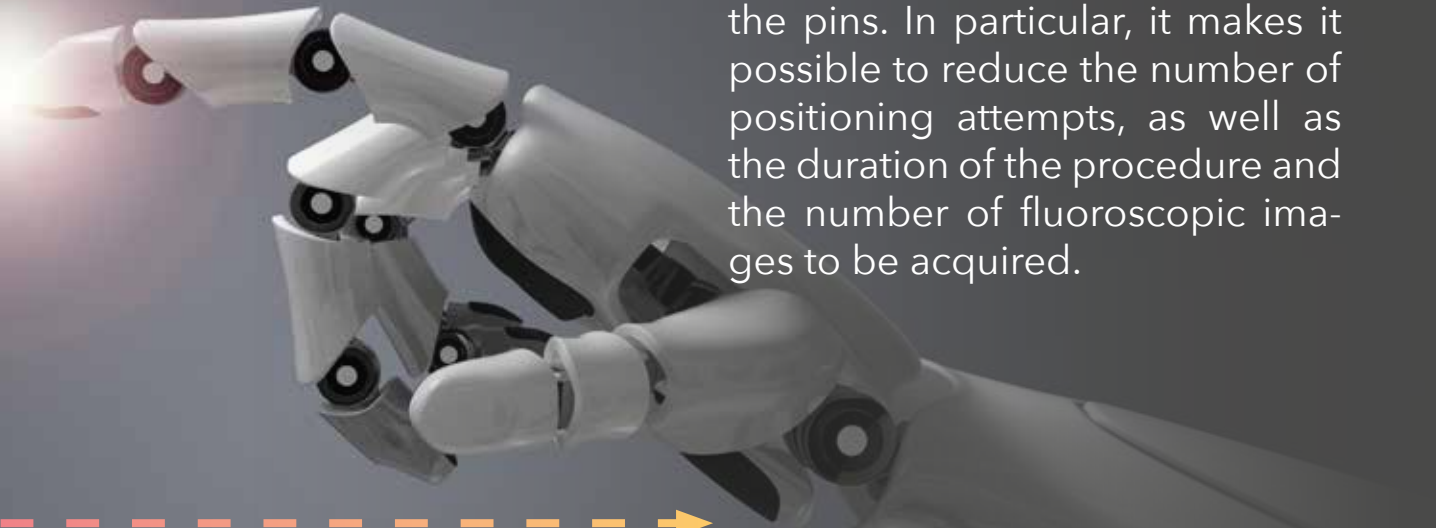

the pins. In particular, it makes it possible to reduce the number of positioning attempts, as well as the duration of the procedure and the number of fluoroscopic images to be acquired.

Studies conducted on fractures located at different points [1,2,3] have shown that the use of a guide image provided by a software system is very useful for positioning

The ESG function was developed to provide real-time guidance for the positioning of pins. If the presence of a pin is detected in the fluoroscopic image, the ESG reconstructs its trajectory and displays it in real time superimposed on the current fluoroscopic image.

**The user can view the trajectory superimposed on the current fluoroscopic image.**

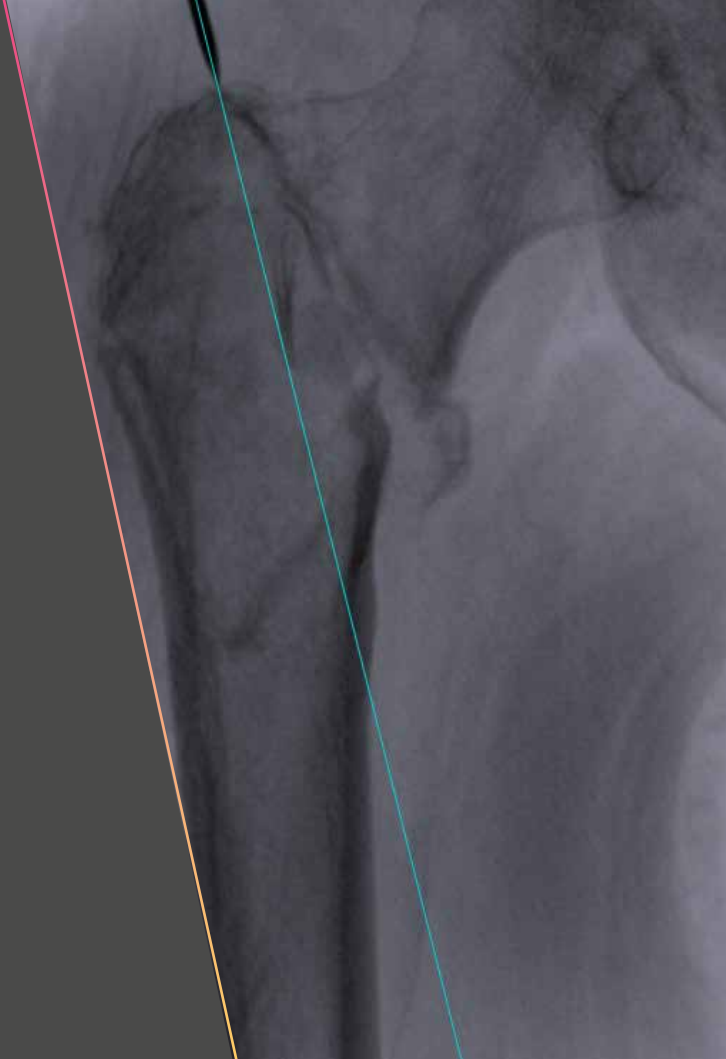

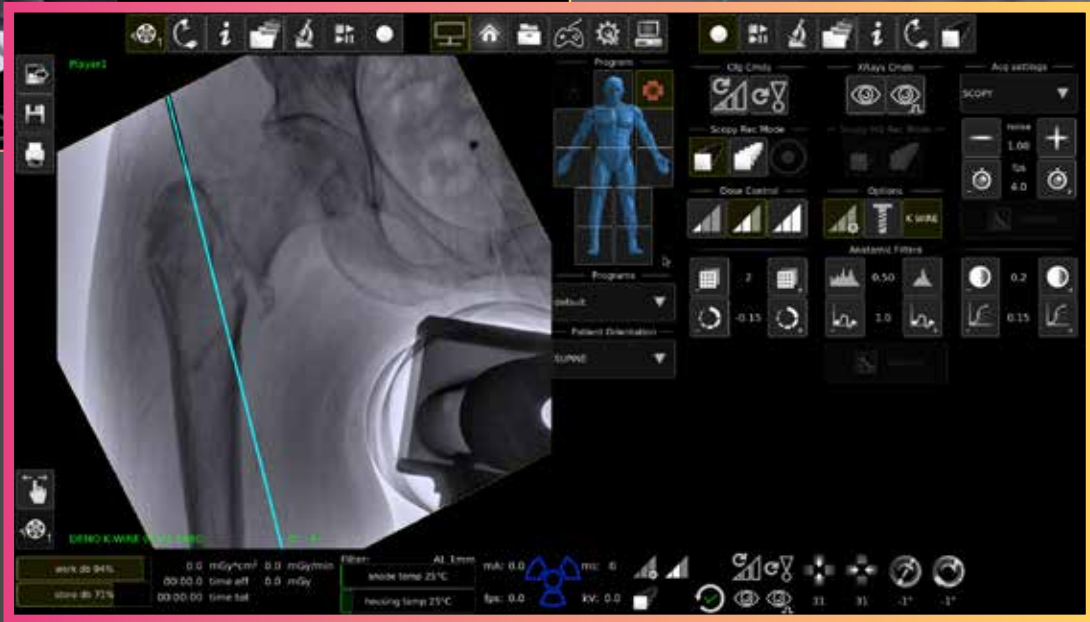
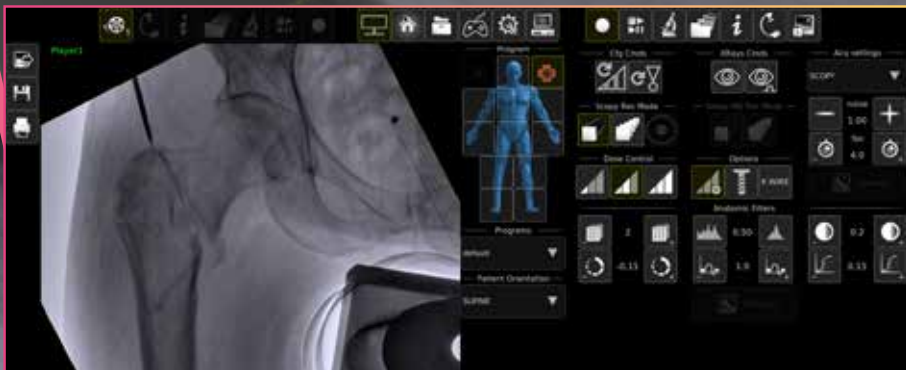

# *CT70T evolution*

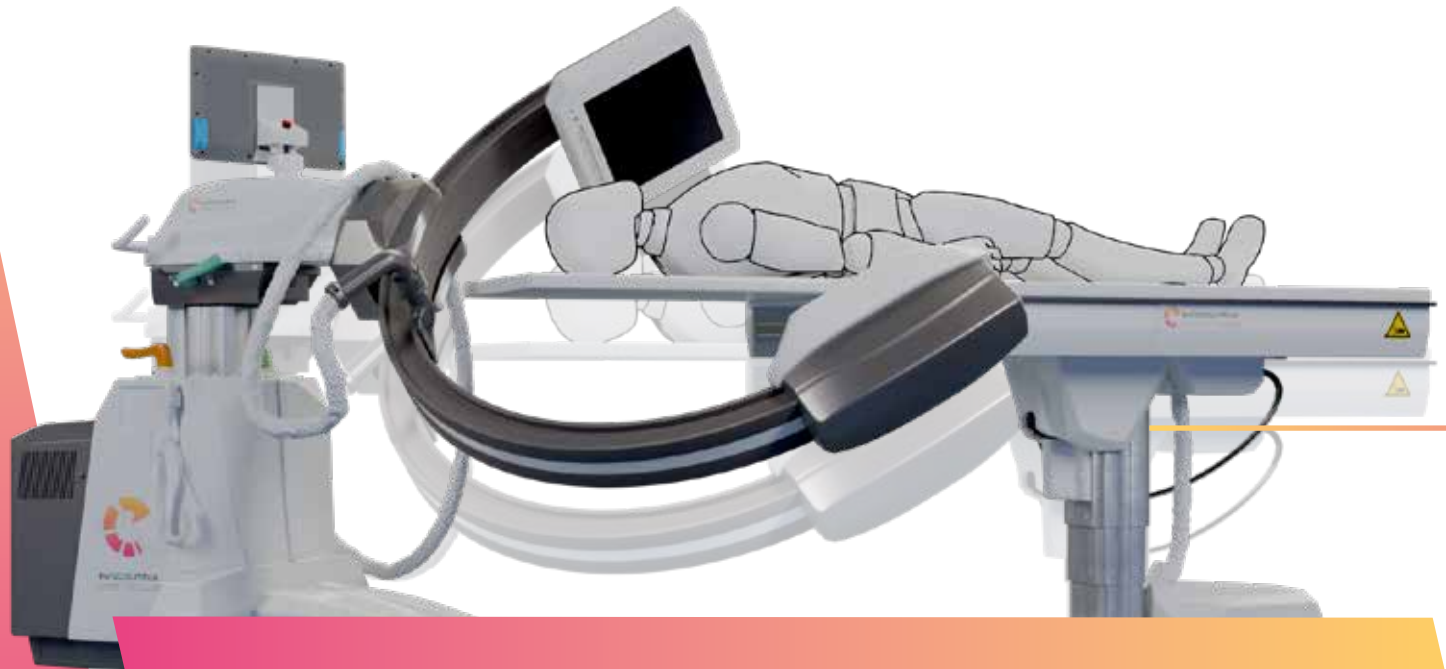

**CT70T IMAGING TABLE INTERFACE SYSTEM** (optional)

We were the first to create a connecting interface between the C-arms and the imaging bed, in order to manage the vertical movements of the two systems at the same time and in a way that could be ergonomic and comfortable for both the operator and the patient. The interface is a fundamental prerequisite for working with the FUSION software.

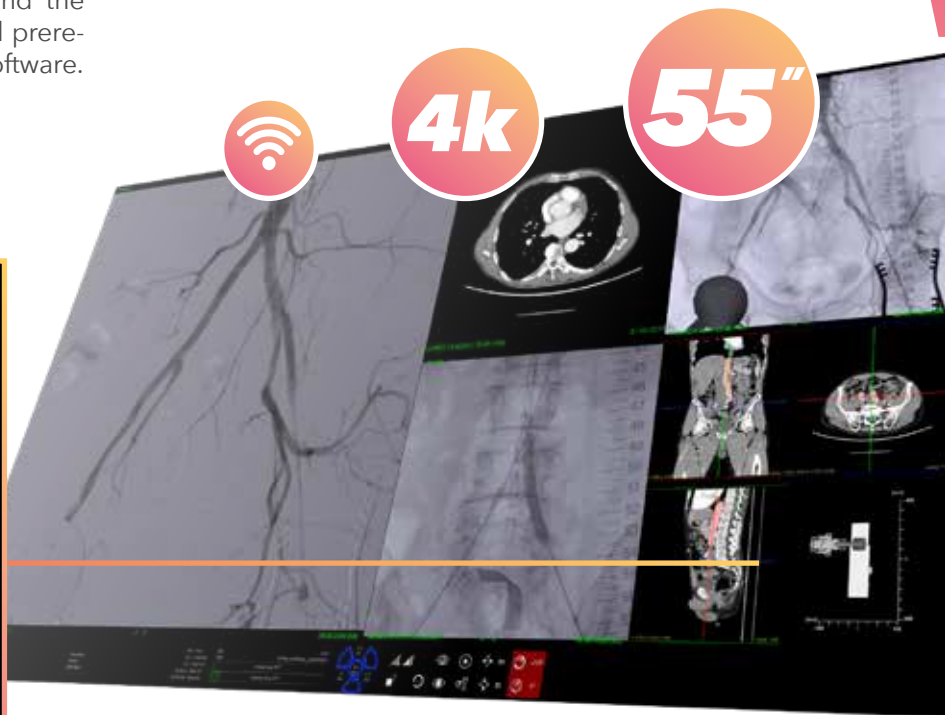
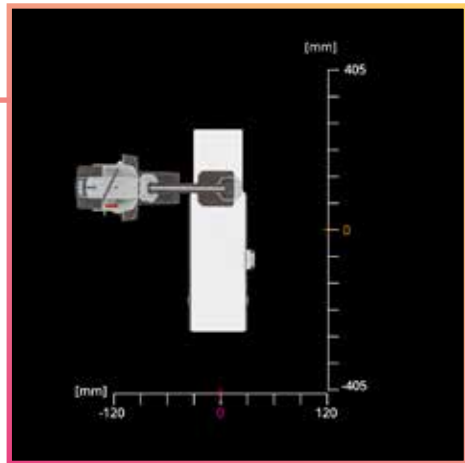

# SOFTWARE FUSION / DSA / C02 available on alien X 3D ready

**FUSION** reduces the dose of the X-ray, the administered amount of the contrast medium and the duration of the surgical procedure, significantly reducing risks for the **patient**.

FUSION allows the 3D visualisation of the operating districts and in real time of the instruments (catheters, stents, prostheses and others) and also allows the simultaneous visualisation of the blood vessels, guiding the surgeon with extreme precision in the positioning of the prosthesis. With the use of pre-operative 3D images, FUSION minimises the need for



subtractive X-ray acquisitions in real time, with a consequent reduction in procedure times, the dose of the X-ray and, last but not least, the quantity of the contrast media.

EuroColumbus is the only company in the world to have developed FUSION technology integrated into C-arms: a great source of Italian pride!

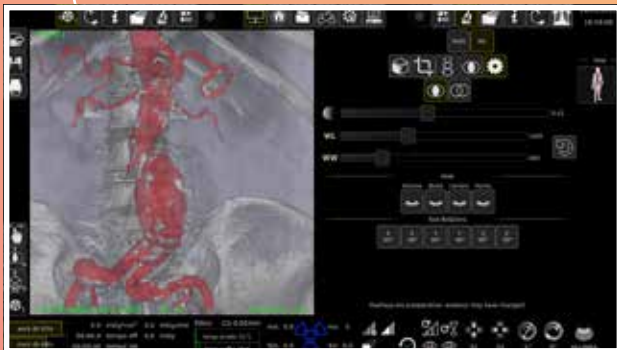

Among the most advanced features of the alien X 3D Ready is the DSA system and the CO2 software package, developed to optimise angiography and reduce risks for patients.



### **DSA** (Digital Subtraction Angiography)

Our DSA software is an advanced system that uses an innovative pulsation method called **EPI** to significantly reduce the dose of radiation, avoiding motion artefacts. This improvement makes angiography safer, while maintaining image quality.



**CO2** is a software package that uses carbon dioxide (CO2) for angiographs instead of the traditional iodine-based contrast medium. It is a particularly useful technique for patients with allergies or kidney failure, as it avoids the risks associated with the use of the iodised contrast medium.





## 4.0

**We manage assistance in an innovative way, respecting privacy and in line with the GDPR directives, following the “enterprise 4.0” approach.**

A server, installed at the Eurocolumbus assistance centre, can connect via the web to radiological equipment in hospitals around the world.

The assistance center will constantly monitor the correct functioning of the equipment around the clock and in real time and, if necessary, will intervene remotely on the software to solve or prevent problems.

**Our engineers will interact in multimedia mode with hospital or technical staff to provide support or instructions, for example in the event of hardware failures.**



COMPLIANCE



eurocolumbus  
C-ARM EVOLUTION

## *A Made in Italy story*

Eurocolumbus was founded in 1972 and began to grow exponentially as from 2004, when the Flat Panel Detector on C-arms was introduced for the first time in Italy. In the following years the products were fully updated and renewed, maintaining the original characteristic which was based on an iso-centric C-arm,

motorised and made safe thanks to anti-collision sensors and a generator separate from the X-Ray tube. Eurocolumbus is still today the only Italian

company producing C-arms that can claim to have its own, proper in-house Research and Development centre. The equipment is entirely designed and produced in the Milan factory (Italy). In 2016, Eurocolumbus entered into a partnership with an important group that invests a very high percentage of its turnover in Research and Development in Italy.







**eurocolumbus**  
C-ARM EVOLUTION

Eurocolumbus srl  
via Filargo, 36  
20143 Milano, Italy  
[www.eurocol.it](http://www.eurocol.it)